

COMPONENT	MATERIAL	HEAT TREAT	FINISH
BEARING	300 SERIES STAINLESS STEEL	NONE	PASSIVATED AND/OR TESTED PER ASTM A380
RETAINER	THROUGH HARDENED CARBON STEEL	NONE	SEMI-BRIGHT ELECTROLESS NICKEL PER ASTM B733

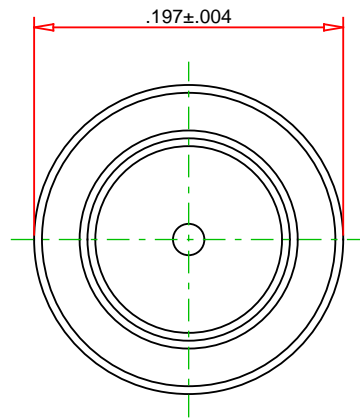

RECOMMENDED  
INSTALLATION  
TOOLING

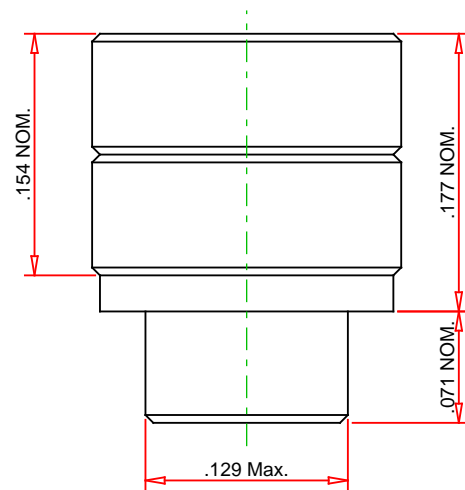
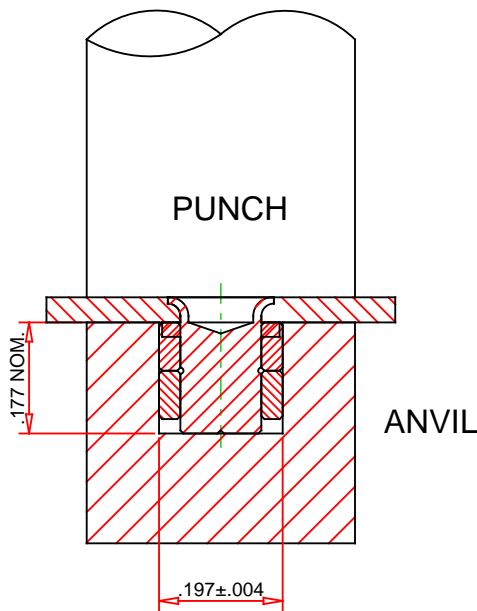

© 2024 PennEngineering

ALL DIMENSIONS IN INCHES

DATE 9-APR-2024

NOTE : DRAWING NOT TO SCALE

THREAD :	NONE	MOUNTING HOLE DIA. :	$.130 + .003 - .000$
MATERIAL :	SEE TABLE	PANEL THICKNESS :	$.040$ MINIMUM
HEAT TREAT :	SEE TABLE	MAX. PANEL HARDNESS :	NO LIMIT
FINISH :	SEE TABLE	MIN CENTERLINE-TO-EDGE :	$0.177$

DESCRIPTION :  
Flaring Roller Bearing Fasteners



PennEngineering®

PART NO. :  
PFTRFS-5.0-1.0

EMAIL: [TECHSUPPORT@PEMNET.COM](mailto:TECHSUPPORT@PEMNET.COM)  
WWW.PEMNET.COM